

COMMERCIAL ITEM DESCRIPTION

PIN, HINGE

THE GENERAL SERVICES ADMINISTRATION HAS AUTHORIZED THIS COMMERCIAL ITEM DESCRIPTION FOR ALL FEDERAL AGENCIES

1. SCOPE: THIS COMMERCIAL ITEM DESCRIPTION (CID) DEPICTS THE REQUIREMENTS FOR A HINGE PIN.
2. SALIENT CHARACTERISTICS.
 - 2.1. THE MATERIAL SHALL BE STAINLESS STEEL SPRING WIRE. TYPE 302 (UNS S30200), 304 (UNS S30400), 316 (UNS S31600) IN ACCORDANCE WITH ASTM A313.
 - 2.2. SURFACE TREATMENT: CRES PINS SHALL BE PASSIVATED IN ACCORDANCE WITH QQ-P-35.
 - 2.3. LUBRICATION: WHEN SPECIFIED, SHALL BE SOLID FILM LUBRICANT IN ACCORDANCE WITH MIL-L-46010.

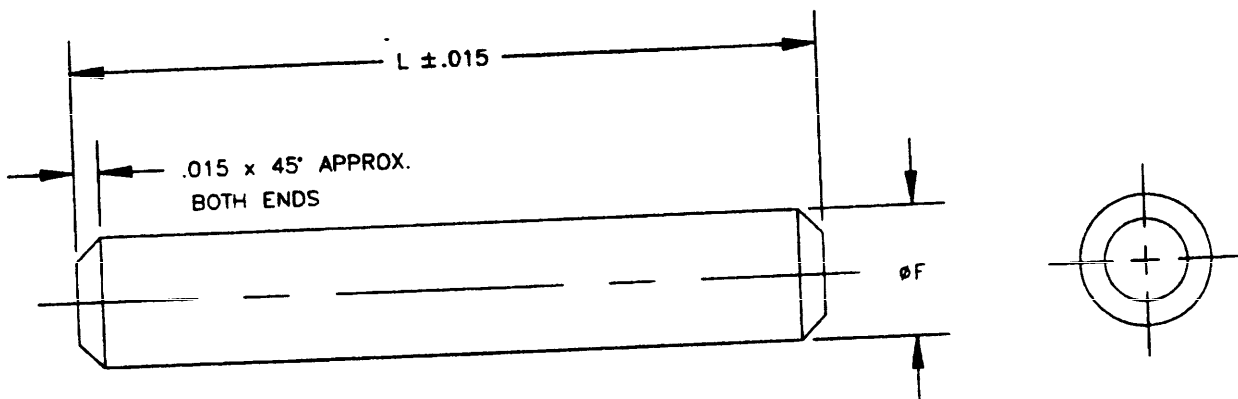

BENEFICIAL COMMENTS, RECOMMENDATIONS, ADDITIONS, DELETIONS, CLARIFICATIONS, ETC., AND DATA WHICH MAY IMPROVE THIS DOCUMENT SHOULD BE SENT TO: DEFENSE INDUSTRIAL SUPPLY CENTER. ATTN: DISC-ECA, 700 ROBBINS AVENUE, PHILADELPHIA, PA 19111-5096.

ASMC N/A

1 OF 2

FSC 5315

DISTRIBUTION STATEMENT A. APPROVED FOR PUBLIC RELEASE; DISTRIBUTION IS UNLIMITED.

TABLE I. DASH NUMBERS AND DIMENSIONS.

CID-PIN	ØF ±.001
-1	.062
-2	.089
-3	.117
-4	.179
-5	.129

3. QUALITY CONFORMANCE PROVISIONS:

- 3.1. THE SUPPLIERS SHALL BE RESPONSIBLE FOR THOSE IN PROCESS CONTROLS AND INSPECTIONS NECESSARY TO SUPPLY A PRODUCT CONSISTENTLY CONFORMING TO THE REQUIREMENTS OF THIS DOCUMENT.
- 3.2. UPON REQUEST, THE SUPPLIER WILL CERTIFY WITH DOCUMENTED TEST/INSPECTION EVIDENCE, THAT THE PART SUPPLIED MEET THE REQUIREMENTS OF THIS DOCUMENT.

4. NOTES:

- 4.1. ALL DIMENSIONS ARE IN INCHES.
- 4.2. REMOVE ALL BURRS AND BREAK SHARP EDGES.
- 4.3. PART IDENTIFICATION NUMBER (PIN) SHALL CONSIST OF THE BASIC COMMERCIAL ITEM NUMBER FOLLOWED BY A DASH NUMBER FROM TABLE I.

EXAMPLE: AA55486 - 1 625 L - PIN, CRES, PASSIVATED, Ø.062, 6.250 LONG, SOLID FILM LUBRICANT.

"L" DENOTES SOLID FILM LUBRICANT
 ABSENSE OF LETTER DENOTES UNLUBRICATED
 DENOTES LENGTH IN HUNDREDTHS OF AN INCH
 DIA. DASH NUMBER (SEE TABLE I)
 BASIC CID NUMBER

TABLE II. CROSS - REFERENCE TABLE.

CANCELLED MS PIN	REPLACEMENT CID PIN
MS20253 - * 1/	AA55486 - * 1/

1/ * REPRESENTS THE SAME DESIGNATION CODES FOR BOTH MS AND CID PINS.

MILITARY INTERESTS
CUSTODIANS
 NAVY - AS
 AIR FORCE - 82

PREPARING ACTIVITY
 DLA-IS

PROJECT NUMBER: 5315-0486